

Technical Specifications / Engineering Submittals

Raritan Model Number: PX3TS-1875CR

rev20230316

LINE DRAWING

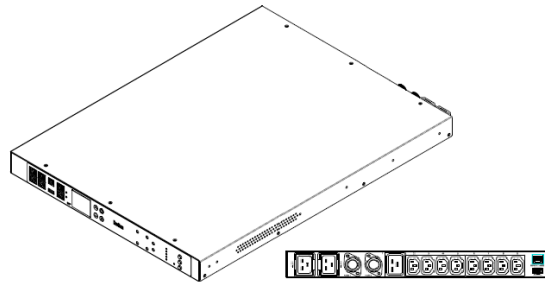

Transfer Switch Characteristics

Transfer speed	Load transfer time 4-8ms
Switching Technology	Patent-Pending hybrid design uses electromechanical relays and silicon controlled rectifiers (SCR) to transfer a load between sources
Robust Switch Circuitry	Oversize 48A relays, 70A SCR (Silicon Controlled Rectifiers)
Out Of Phase Transfers	Reliable transfer when power in or out of phase
Power Quality Transfers	Transfers when voltage/frequency is outside user configurable range
User Configurable Setting	Voltage, Frequency and Phase angle

Metering

Energy Metering	Voltage (V), Current (A), Active Power (kW), Real Power (kVA), Energy (kWh), Power Factor
Metering Accuracy	ISO/IEC 62053-21 1%
Metering per Input Line	Yes
Metering per Branch Circuit Breaker	No
Metering per Output Receptacle	No
Remote Outlet Switching	No
Environmental Sensor Ready	Yes
Replaceable Controller	No
Onboard Display	Transfer switch status and controls, energy meter, alarms

Technical Specifications / Engineering Submittals

Raritan Model Number: PX3TS-1875CR

rev20230316

Compatible Sensors	Temperature, Humidity, Air Flow, Differential Pressure, Water Leak, and Contact Closure
Networking	Gigabit (10/100/1000 BaseT) Ethernet port; secondary, redundant (10/100 BaseT) Ethernet port. Optional WiFi (802.11a/b/g/n)
Remote Management	HTTP(s); SSH; Telnet; RS-232(Serial); SNMP Versionv2/v3; SMTP; JSON-RPC, PowerIQ, Modbus RTU
Cascading	Yes, Max 16 PDUs can be daisy chained using a single Ethernet or USB connection
Embedded Processor	ARM Cortex A5 536MHZ (Atmel A5D35A), 16MB SPI Flash, 64MB DDR2 RAM

Input

Input Connections	(2) IEC 60320 C20 16A 2P3W (L1/L2/E) IP44("splashproof")
Cord Length	3.0 meters
Maximum Input Current	16A (per line)
Rated Input Current	16A (per line) (North America)
Rated Input Voltage	200 - 240V, Single phase
Input Frequency	50/60Hz
Load Capacity	3.2kVA at 200V, 3.8kVA at 240V

Output

Output Connections	a. (8) C13 2-pole, 3-wire; 10A b. (1) C19 2-pole, 3-wire; 16A
---------------------------	--

Circuit Protection & Supervisory Alarms

Protection	Inlet surge protection & field replaceable fast blow fuses for load short circuit protection
-------------------	--

Technical Specifications / Engineering Submittals

Raritan Model Number: PX3TS-1875CR

rev20230316

Physical

Unit Dimensions (W x D x H)	17.3" x 27.0" x 1.7" ; 440mm x 685mm x 44mm
Shipping Dimensions (W x D x H)	22.13" x 5.75" x 31.97" ; 562mm x 146mm x 812mm
Color	Black powder coat
Mounting	RACK-KIT-PX3TS-1U-W_550MM

Environmental

Operating Environment	5 - 50°C (41 - 122°F)
Operating Relative Humidity	5 - 85%
Operating Elevation	0 - 10000ft

Conformance

Regulatory Approvals	CE, RoHS, Canada ICES-003
----------------------	---------------------------

Technical Specifications / Engineering Submittals

Raritan Model Number: PX3TS-1875CR

rev20230316

Control Panel Detail



Transfer Switch Status, Control & Alarms

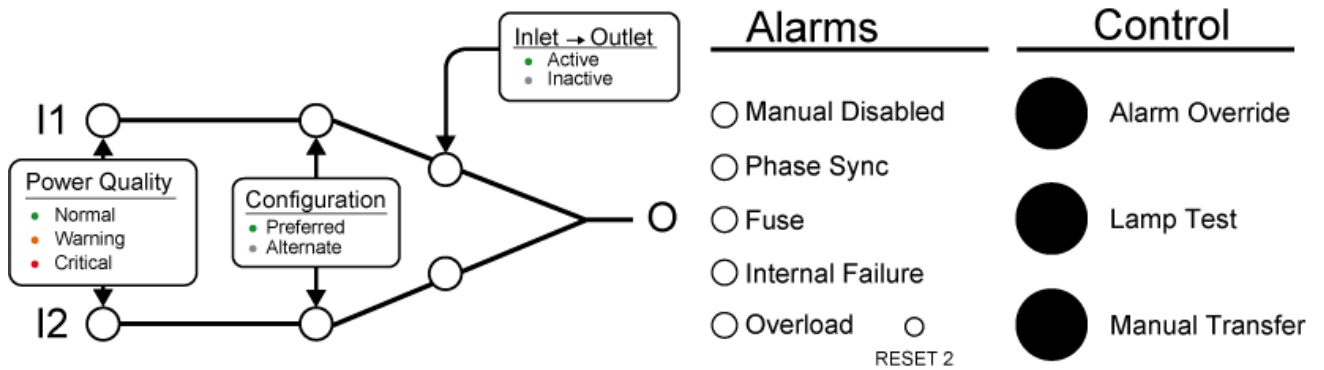

Technical Specifications / Engineering Submittals

Raritan Model Number: PX3TS-1875CR

rev20230316

Mechanical Diagram

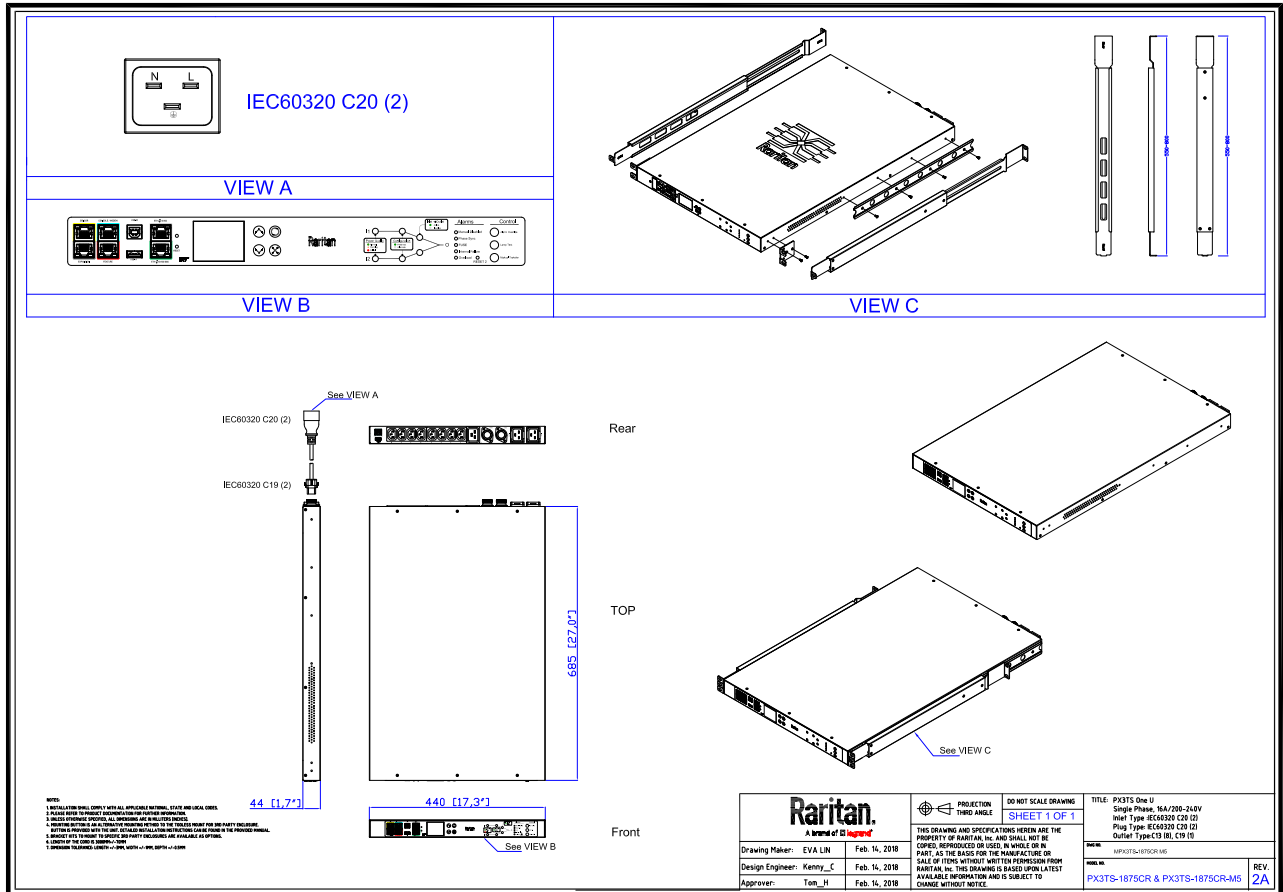

This file generated on: Thu, March 16, 2023 - 10:10:03